

how it works...

In simple terms the TwinTec Vario ride-on rewrites the mathematical rule book, proving once and for all that **Three Into One Does Go!**

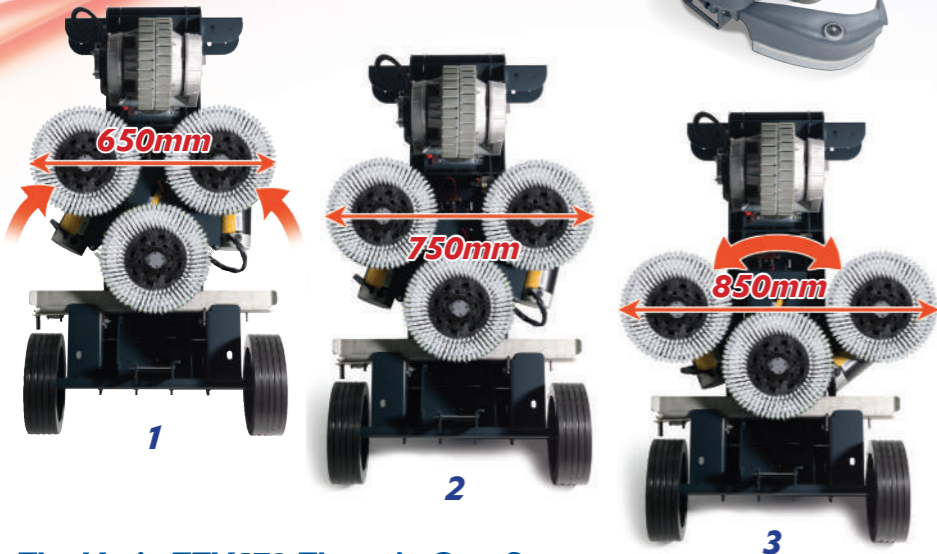

The Vario TTV678 Three in One System

Yes one machine which can be set to 3 different working widths: 650mm, 750mm and 850mm and all at the flick of a simple selection lever. This doesn't even need tools – anybody can do it at any time. You want it wide – fine ... you want it narrow – 30 seconds is all that it takes.

In many applications changing circumstances change specific needs, so with the Vario you can change the specification to suit your exact requirements. It's not only the working widths that can be changed; it's the full operating performance that is under the driver's complete control – cleaning speed, brush speed, water flow and chemical dosing, nothing left to chance.

Decide what you want and that's what you will get.



TTV678

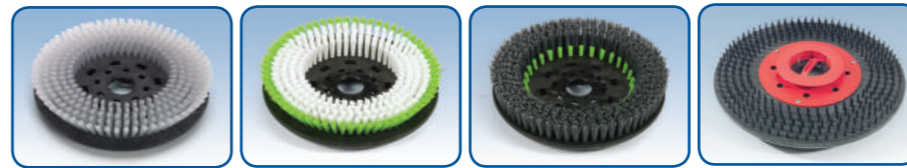
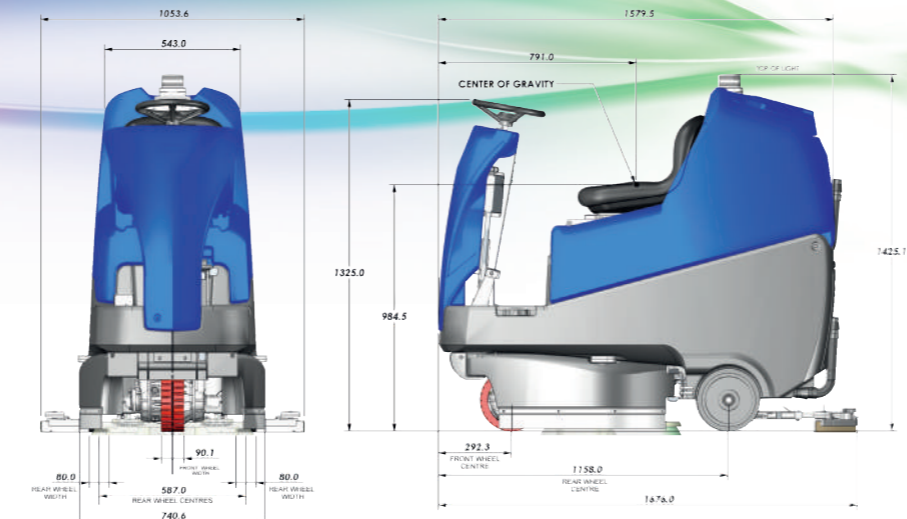

300mm Octo Nyloscrub Brush (3 Required) 300mm Octo Polyscrub Brush (3 Required) 300mm Octo Longlife Brush (3 Required) 300mm PadLoc Drive Board (3 Required)

Brush motor	Vac motor	Power	Run time	Traction drive	Drive speed	Cleaning speed	Climbing gradient	Scrub widths
3x24V 400W	24V 400W	6 x 12V (24V) = 300Ahr 8 x 12V (24V) = 400Ahr (Optional)	3.5 Hrs 4.5 Hrs	600W	7.0km/h	4.2km/h	11%	650mm 750mm 850mm

Brush speed	Water capacity	Nuchem capacity	Water flow rate	Nuchem mix	Gross weight (full)	Dimensions (HxLxW)
150/200rpm	120L	Optional 5L	4L/min 3L/min 2L/min 1L/min	25:1 50:1 75:1 100:1	6x12V+614kgs 8x12V+684kgs	1676x1425x1054mm

TTV678

Versatile cleaning... by design



- www.numatic.co.uk
- www.numatic.de
- www.numatic.ch
- www.numatic.fr
- www.numatic.nl
- www.numatic.co.za

Numatic International Limited, Chard, Somerset, TA20 2GB Tel: 01460 68600 Fax: 01460 68458
Numatic International Limited 2013. Specification subject to change without prior notice. PN 233905/0313

TwinTec Vario...678

A comfortable, driver friendly, 120-litre, front wheel drive machine with a fantastic turning radius, gets in and out of places other machines just won't go.

TTV678

The TwinTec Vario "three in one" (3 in 1) design has proved itself to be almost the perfect balance between sound common sense engineering and innovative and truly functional technology.



Ride with performance and versatility

The unique arrangement of 3 independent scrubbing heads which, by virtue of a simple adjustment mechanism, can provide a choice of scrubbing widths which, with the addition of a selection of brushes and pads, can provide customized performance on almost any surface in application.

Dosing presets make user operation even easier, allowing correct chemical dosing selection every time for every task.

With the Vario you don't invest in a single ride-on and hope it works, you buy into a truly variable cleaning machine that, by virtue of its design, allows optimization of cleaning performance and efficiency to suit an almost limitless range of applications.



Control panel

Vario, the machine that gives you what you want.



Easy battery access



Vario 3-in-1 Brush drive and access system

The unique 3 brush system is easily accessible for brush or pad changes and the swing out brush covers give a unique form of sidewall protection acting as integrated shock absorbers during operation. Battery access is simple and functional too.